

POISON SPYDER

C U S T O M S

LED LOAD RESISTOR KIT

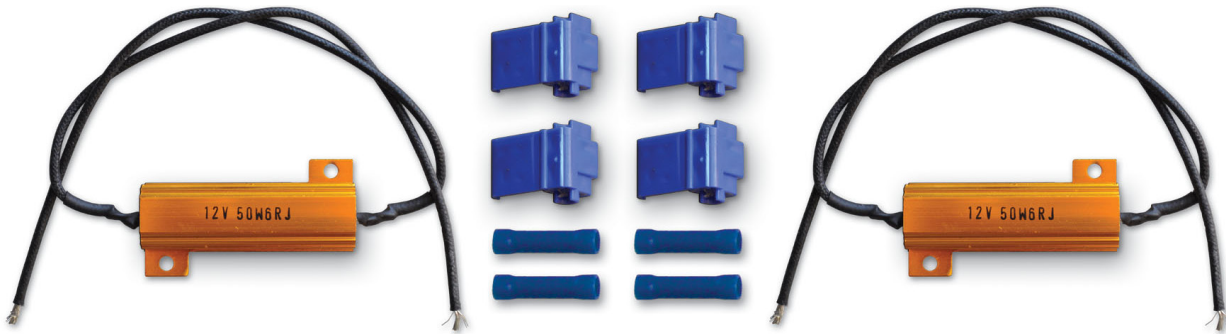

LED lamps draw much less current than standard incandescent lamps. On some late model vehicles, this variation can cause the turn signals to flash at an abnormal rate and/or cause error codes in the electronics system. This kit is designed to simulate the load of incandescent lamps in order to correct these problems. Installation is fairly simple with the right tools and good mechanical/electrical abilities. If you are not confident in your skills, please seek the help of a professional to perform the installation. Please read through these entire instructions before proceeding with installation.

PARTS LIST

Please check your packages immediately upon arrival to ensure that everything listed is included, and to check for damage during shipping. If anything is missing or damaged, call Poison Spyder at (951) 849-5911 as soon as possible.

- (2) Load Resistor with lead wires
- (4) 18-14 Ga. Wire Tap Connectors
- (4) 18-14 Ga. Butt Connectors

TOOLS NEEDED

- Electrical multi-meter or test light
- Electrical wire cutter/crimper
- Channel-lock pliers

BEFORE YOU BEGIN

These Load Resistors are primarily used in conjunction with LED taillights on JK Jeeps, which are a commonly used with Poison Spyder Crusher Corners. It is assumed that installation

of the LED's is already completed, either as part of a Crusher Corner installation or by some other method. These instructions only cover the installation of the Load Resistors themselves.

The following procedure assumes installing these Load Resistors in conjunction with the specific LED Taillights and Pigtails sold by Poison Spyder Customs.

The Load Resistors install behind the LED taillight assembly, inside the body panels of the Jeep, on either side of the Jeep (behind each taillight). If the LED Taillight is already installed, remove it to gain access to the space behind it and the OE wiring.

INSTALLATION PROCEDURE

1. **Park vehicle on a level surface**, place the transmission in gear or park and set the emergency brake.
2. **Reach through the LED taillight hole** and locate the taillight wiring section of the OE wiring harness. It will either be cut or have the OE plug from where it attached to the OE taillight assembly. Carefully pull as much of the harness out through the hole as possible without damaging it, making it easier to work on the wiring.
3. **Identify which wires in the harness** is the hot lead for the running lights and for the stop/turn lights. Use a test light or multi-meter to ID these wires. Turn the running lights on and probe each wire until you find the "hot" one. Then turn on the turn signal for whichever side you're working on to determine which wire is correct for that circuit.

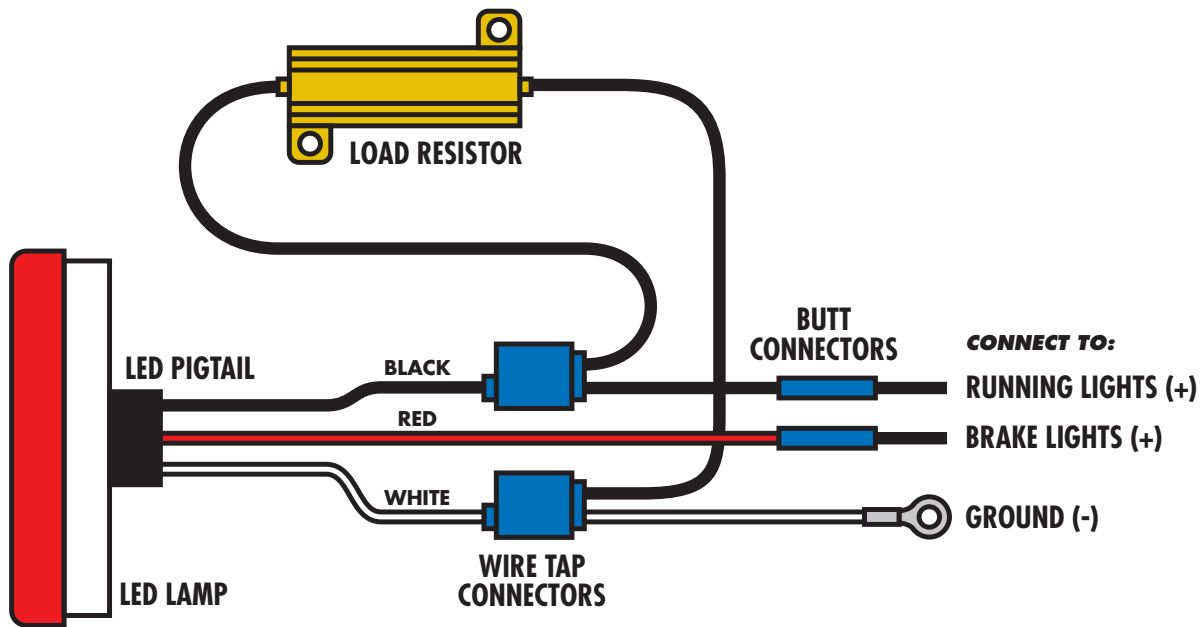

4. **Study the diagram** at the top of page 2 of these instructions. Note that there are three wires in the pigtail coming from the LED taillight: black, red and white.
4. **Used one of the Wire Tap Connectors** to tap one of the Load Resistor leads into the BLACK wire from the LED Pigtail. These Wire Tap Connectors work by piercing through the wire insulation. To install them, slide the through-wire (in this case, the black wire from the LED Pigtail) through the slot in the connector that goes all the way through. Leave a few inches of the black wire poking through the other side of the connector. Then insert the lead from the Load Resistor (it doesn't matter which one) into the non-through slot in the connector, and push it in until it hits the internal stop. Next, use the channel-lock pliers to crimp the metal tang down into the connector, which pierces the insulation and completes the tap. Finish by clasping the connector's cover shut.
5. **Use a Butt Connector** to connect the end of the black wire to the Running Lights hot lead in the OE harness, which you identified in Step 3.
6. **Use the other Wire Tap Connector** to tap the remaining Load Resistor lead into the WHITE wire in the LED Pigtail. Repeat the procedure from Step 4 for installing the Wire Tap Connector.
7. **Attach the ring terminal** at the end of the white wire to a suitable ground.
8. **Use the remaining Butt Connector** to connect the end of the red wire in the LED Pigtail to the Brake Lights hot lead in the OE wiring, which you identified in Step 3.
9. **With these connections completed**, plug the LED Lamp into the LED Pigtail and test operation of the running lights, stop, and turn lights. If they do not work correctly, check all of your connections and the routing of your wiring, using the diagram above for reference.
10. **Affix the Load Resistor** to some stationary location inside the body panel. Note that it can develop heat, just like the incandescent lamp it is simulating, so be careful not to mount it to or near anything that can melt or be damaged by heat, such as other wiring, plastic items, painted surfaces, etc.
11. **Re-install the LED Lamp** into place.
12. **Repeat steps 2 through 11** for the other side.

WARRANTY

Poison Spyder Customs™ warranties all of the products we sell and distribute for one (1) year from the date of sale. These products will be free from defects in material and workmanship under normal installation, and use. Due to the intended use the powder coat finish is warranted for ninety (90) days. The finish warranty will not cover a product if it has been damaged in any way. Warranty is limited to repair or replacement. Poison Spyder Customs™ does not offer any type of labor or shipping allowance and all warranty claims are subject to inspection by Poison Spyder Customs™.

At the discretion of Poison Spyder Customs™, the products in question can be repaired or replaced when found defective. Prior to any replacement or repair, written authorization must be obtained from Poison Spyder Customs™. Failure to contact us prior to having warranty work preformed will immediately void all applicable warranties; and it is then the sole responsibility of the customer to remit any payment incurred.

The warranty expressed above is the sole warranty of Poison Spyder Customs™, and any other expressed or implied warranties are hereby specifically excluded and disclaimed.

HOLD HARMLESS AGREEMENT

1. In purchasing a Poison Spyder Customs Product™ I release, waive, discharge and covenant not to sue Poison Spyder Customs officers, servants, agents, or employees (hereinafter referred to as Releasees) from any and all liability, claims, demands, actions and causes of action whatsoever arising out of or related to any loss, damage, or injury, including death, that may be sustained by me (or anyone else), any property belonging to me (or anyone else), whether caused by the negligence of the releasees or otherwise, while working on, using or any activity related to this product.
2. I am fully aware of risks and hazards connected with the use of a this product and I elect to voluntarily engage in such use of this product knowing that the use may be hazardous to me and my property. I voluntarily assume full responsibility for any risks of loss, property damage or personal injury, including death,

that may be sustained by me (or anyone else), or any loss or damage to property owned by me (or anyone else), as a result of using this product, whether caused by the negligence of releasees or otherwise.

3. I further agree to indemnify and hold harmless the releasees from any loss, liability, damage or costs, including court cost and attorney fees, that they may incur due to my use of a this product, whether caused by negligence of releasees or otherwise.
4. It is my express intent that this Release and Hold Harmless Agreement shall bind the members of my family and spouse, if I am alive, and my heirs assigns and personal representative, if I am deceased, and shall be deemed as a release, waiver, discharge, and covenant not to sue the above named releasees. I further agree that this Waiver of Liability and Hold Harmless Agreement shall be construed in accordance with the laws of the State of California.

By accepting this product, I acknowledge and represent that I have read the above Waiver and Liability and Hold Harmless Agreement, understand it and accept it voluntarily as my own free act and deed; no oral presentations, statements, or inducements, apart from the foregoing written agreement, have been made; I am at least eighteen (18) years of age and fully competent; and I execute this Release for full, adequate and complete consideration fully intending to be bound by same.

If you do not agree with the preceding Hold Harmless Agreement, you may return the product and receive a full refund. Please, contact a Poison Spyder Customs™ sales representative and they will issue a call tag for the product in question. Once the product has been received by Poison Spyder Customs™ a full refund will be issued.

INSTALLATION INSTRUCTIONS